

SM82 Switch Mode Range of Automatic Battery Chargers



- **High rate duty float charging:**
5A@12V - 3A or 5A @ 24V - 2A@36V - 1.25A@48V
- **Fully automatic charge regulation**
- **Light compact DIN rail mount design**
- **Optional boost mode**
- **Standard Charge Fail relay output**

Description

The SM82 is a highly efficient high performance charger. The very smooth output is configured for accurate fast charging, optimum battery life and reliability. The charger is designed for continuous float charging and standby battery applications. Due to its very smooth output (<1% ripple) the charger is suitable for sealed and vented batteries (e.g., nickel cadmium (NiCD), lead acid sealed (VRLA), vented and plante cells.

Switch mode technology is a major advance in power supply and battery charger design, giving low heat dissipation, compact low weight design and ease of panel installation. Utilizing the benefits of switch mode, the charger will give a constant current output up to its knee point (13 volts on 12 volt LA) and then ramp down to its float voltage. This gives an optimum charge time to ensure that the battery voltage is maintained at the pre-calibrated float level while supplying any additional standing load current up to a specified maximum.

Boost Option

A 'boost' mode of operation provides increased voltage output. Selection of boost mode is via two terminals, allowing activation by a time delay relay or switch. The calibration table on the reverse side shows details of float and boost voltages.

Charge Fail Option

A self-diagnostic 'charge fail' circuit and relay output can be provided. The volt free relay de-energizes in the event of a charging fault or loss of AC input.

Electrical connections of the AC supply, DC output and charge fail relay are via shrouded screw terminals.

Warranty

A one year limited warranty on materials and workmanship is given with this product. Details available upon request.

Product Specification

Power Supply:	
Nominal Operating Voltages	95-135V,AC 195-277V,AC
Nominal Operating Frequency	47-400Hz
DC Charge Output:	
Output Current A,DC	5 5
Nominal Voltage V,DC	24 12
Line Regulation	< 1%
Load Regulation	< 1%
Output Ripple	< 1%
Float / Boost voltages	<i>see reverse side</i>
Charge Fail Output:	
Relay Type	volt free SPDT contacts relay de-energized on fault
Contact Rating	1A@30V,DC (resistive load)
General:	
Operating Temperature	14 to +131°F (-10 to +55°C)
Overall Dimensions	5.2" x 5.1" x 3.2"
Weight	1.24 lbs.
Mounting	see Note on reverse side
EMC Emission / Immunity	EN58801-2 / EN50082-2

Electrical connection

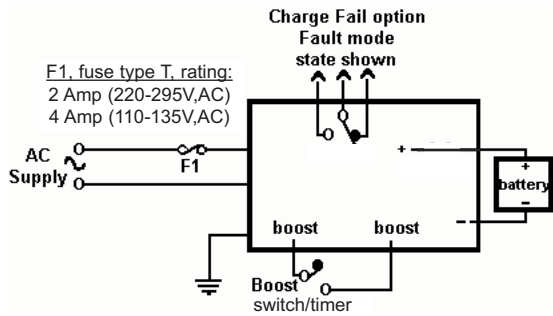

Notes:

- 1) battery output is isolated from chassis.
- 2) chassis must be connected to a low impedance earth.

Calibration

Battery Type*		Float Volts (V,DC)	Boost Volts (V,DC)
12V	Lead Acid (6 cells)	13.6	14.1
	NiCd (10 cells)	14.1	16.0
24V	Lead Acid (12 cells)	27.2	28.2
	NiCd (18 cells)	25.38	28.8
	NiCd (20 cells)	28.2	32.0

The above are factory standard settings. Specials are available on request.

Dimensions

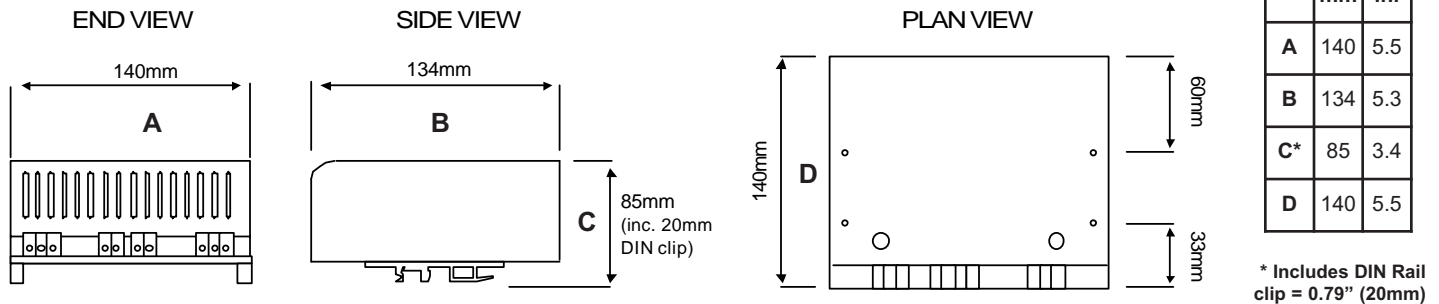

How to Order

When ordering, please specify --

Product	Nominal Output V,DC				Nominal Output Current			
	12	24	36	48	5	3	2	1.25
SM821205	■				■			
SM822405		■			■			
SM822403		■				■		

INPUT VOLTAGE		
Code	95-135V,AC	195-277V,AC
C	■	
D		■

Product	BATTERY TYPE			
	Lead Acid	10 Cell NiCd	18 Cell NiCd	20 Cell NiCd
LA	■			
10		■		
18			■	
20				■

	OPTIONS		
	Manual Boost	DIN Rail Mounting	Protective Cover
MB	■		
DIN		■	
PC			■

Product	Input Volts	Battery type
SM821205	D	LA

The above 3 part number codes must be filled in to complete your order.

Options	Options	Options
MB	PC	

Insert options when required. If no options are required, leave empty.

The above example shows the order code for a 195-277V,AC input 12V@5A,DC output charger calibrated for a vented lead acid battery and with manual boost and protective cover option.

Mounting Note: DIN rail clips are provided as standard when ordering the SM82 range of battery chargers in a protective cover.



For more information and certifications, please contact:

Panel Components & Systems, Inc. ■ Phone: (800) 523-9194

Main Office:	Stanhope, NJ	Phone: (973) 448-9400
South East:	Charlotte, NC	Phone: (704) 535-3357
South Central:	Tulsa, OK	Phone: (862) 258-6974
Canada:	Edmonton, AB	Phone: (877) 962-0557