

Enclosed Sentry Range of UL Automatic Battery Chargers



This document describes the enclosed option for the Sentry range of UL approved chargers.

Description

The Sentry range provides automatic, current limited and thyristor controlled charging of vented lead acid or NiCd batteries. The units may be used in a wide range of industrial charging applications, including standby engines, pumps and generators. The charger comes in a wall mounting enclosure complete with a UL approved ammeter.

Each unit consists of a transformer, rectifier and control circuit. The control circuit ensures that the charger maintains the battery voltage at the pre-calibrated float level, while supplying any additional load current up to the specified maximum.

When used as a float charger, the unit is designed to give a constant current output up to its knee point (approx. 13V on a 12V LA). At which point the current ramps down as the battery reaches its float voltage giving an optimum charge time and ensuring that the battery voltage is maintained at the pre-calibrated float level.

Boost option

A 'boost' mode of operation provides increased voltage output. Selection of boost mode is a link via two terminals, allowing activation by a time delay relay or switch. The calibration table over leaf shows details of float and boost voltages.

Charge fail option

A self diagnostic 'charge fail' circuit and relay output can be provided. The volt free relay de-energizes in the event of a charging fault or loss of AC input. Electrical connection of the AC supply, DC output, boost selector link and charge fail relay are via spring clamp connection.

- **Float Charging**
5A or 7A @ 12V - 3A or 5A @ 24V
- **Simple, low cost design**
- **Lead Acid or Ni-Cd calibrations**
- **DC ammeter**
- **UL Approved**
- **Stainless steel enclosure**
- **Optional charge fail and boost**

Product Specification

Power Supply:

Nominal Operating Voltages	110-120 V,AC(115V Units)
Permissible Voltage Variation	± 6% of nominal
Nominal Operating Frequency	50/60Hz

DC Charge Output:

Maximum Current A,DC	5	7
Nominal Voltage V,DC	24	12
Float / Boost Voltages	see table over leaf	

Charge Fail Output:

Relay Type	volt free SPDT contacts relay energized on fault
Contact Rating	1A @ 30V,DC (resistive load)

Enclosure Features:

Indication	DC ammeter
Mounting	Wall mounted enclosure

General:

Operating Temperature	-10 to +55°C
Overall Dimensions	see table over leaf
Weight	see table over leaf
EMC Emission / Immunity	EN 58801-2 / EN50082-2

Electrical connection

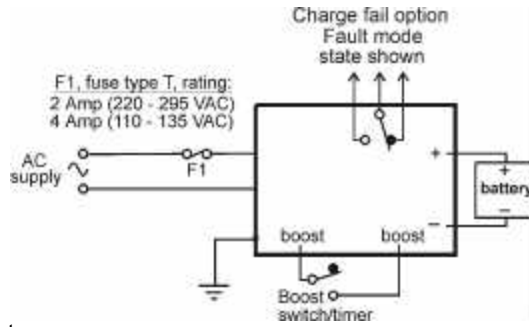

Notes:

- 1) battery output is isolated from chassis
- 2) chassis must be connected to a low impedance earth

Calibration

Battery type		float volts (V,DC)	boost volts (V,DC)
12V	Lead Acid (6 cells)	13.6	14.1
	Ni-Cd (10 cells)	14.2	14.7
24V	Lead Acid (12 Cells)	27.2	28.2
	Ni-Cd (18 Cells)	25.6	26.6
	Ni-Cd (20 Cells)	28.4	29.4

The above are factory standard settings. Specials are available on request.

Dimensions

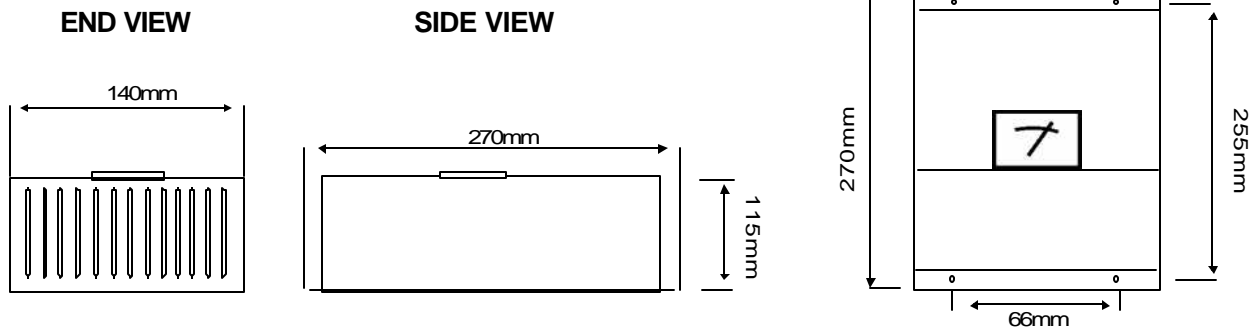

How to order

When ordering, please specify -

PRODUCT	Nominal Output V,DC		Nominal Output Current		
	12	24	3	5	7
ESUL100243		•	•		
ESUL100125	•			•	
ESUL120245		•		•	
ESUL120127	•				•

INPUT VOLTAGE	
CODE	115V,AC
C	•

	BATTERY TYPE			
	Lead Acid	10 Cell Ni Cad	18 Cell Ni Cad	20 Cell Ni Cad
LA	•			
10		•		
18			•	
20				•

OPTIONS		
	Charge Fail	Manual Boost
CF	•	
MB		•

Product	Input volts	Battery type	Options	Options
ESUL100125	C	LA	CF	

The above 3 part number codes must be filled in to complete your order.

Insert options when required, if no options are required, leave empty.

ESUL100125 C LA CF

The above example shows the order code for an enclosed Sentry UL approved 115V,AC input, 12V@5A,DC output charger, calibrated for a vented lead acid battery, and with the charge fail option.

North American Distributor - PC & S / Panel Components & Systems, Inc.		
149 Main Street Stanhope New Jersey 07874 Phone (800) 523 9194 Fax (973) 448 1674	213 Jespersen Avenue Spruce Grove Alberta T7X 2J1 Phone (877) 962 0557 Fax (780) 962 0557	8539 Monroe Road (Suite 104) Charlotte North Carolina 28212 Phone (704) 535 3357 Fax (704) 535 6288