

SM82 Switch Mode Range of Automatic Battery Chargers



(shown in protective cover)



(shown as open frame unit)

- **High rate duty float charging:**
5A@12V - 3A or 5A@24V - 2A@36V - 1.25A@48V
- **Fully automatic charge regulation**
- **Light compact DIN rail mount design**
- **Optional boost mode**
- **Optional charge fail relay output**

Description

The SM82 is a highly efficient high performance charger. The very smooth output is configured for accurate fast charging, optimum battery life and reliability. The charger is designed for continuous float charging and standby battery applications. Due to its very smooth output (< 1% ripple) the charger is suitable for sealed or vented batteries. e.g. nickel cadmium (NiCd), lead acid sealed (VRLA), vented and plant cells.

Switch mode technology is a major advance in power supply and battery charger design, giving low heat dissipation, compact low weight design and ease of panel installation via din rail. Utilizing the benefits of switch mode, the charger will give a constant current output up to its knee point (13 Volts on a 12 Volt LA) and then ramp down to its float voltage. This gives an optimum charge time to ensure that the battery voltage is maintained at the pre-calibrated float level, while supplying any additional standing load current up to a specified maximum.

Boost option

A 'boost' mode of operation provides increased voltage output. Selection of boost mode is via two terminals, allowing activation by a time delay relay or switch. The calibration table over leaf shows details of float and boost voltages.

Charge fail option

A self diagnostic 'charge fail' circuit and relay output can be provided. The volt free relay de-energizes in the event of a charging fault or loss of AC input. Electrical connection of the AC supply, DC output and charge fail relay are via shrouded screw terminals.

Product Specification

Power Supply:

Nominal Operating voltages	95-135V,AC 195-277V,AC
Nominal Operating frequency	47-400Hz

DC Charge Output:

Output Current A,DC	5	5
Nominal Voltage V,DC	24	12
Line Regulation	< 1%	
Load Regulation	< 1%	
Output Ripple	< 1%	
Float / Boost voltages	see table overleaf	

Charge Fail Output:

Relay Type	volt free SPDT contacts relay de-energized on fault
Contact Rating	1A @ 30V,DC (resistive load)

General:

Operating Temperature	-10 to +55°C
Overall Dimensions (w x h x d)	133mm x 130mm x 80mm (5.2" x 5.1" x 3.2")
Mounting	see mtg. note
Weight	0.56Kg (1.24lbs)
EMC emission / immunity	EN 58801-2 / EN50082-2

Electrical connection

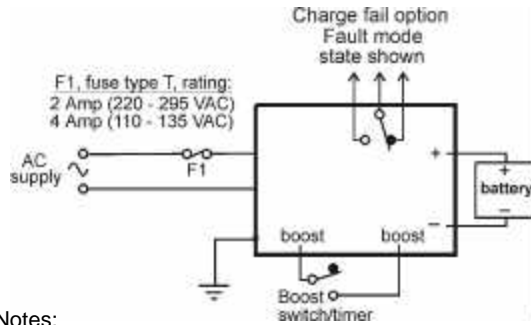

Notes:

- 1) battery output is isolated from chassis
- 2) chassis must be connected to a low impedance earth

Calibration

Battery type		float volts (V,DC)	boost volts (V,DC)
12V	Lead Acid (6 cells)	13.6	14.1
	Ni-Cd (10 cells)	14.2	14.7
24V	Lead Acid (12 Cells)	27.2	28.2
	Ni-Cd (18 Cells)	25.6	26.6
	Ni-Cd (20 Cells)	28.4	29.4

The above are factory standard settings, specials are available on request.

Dimensions

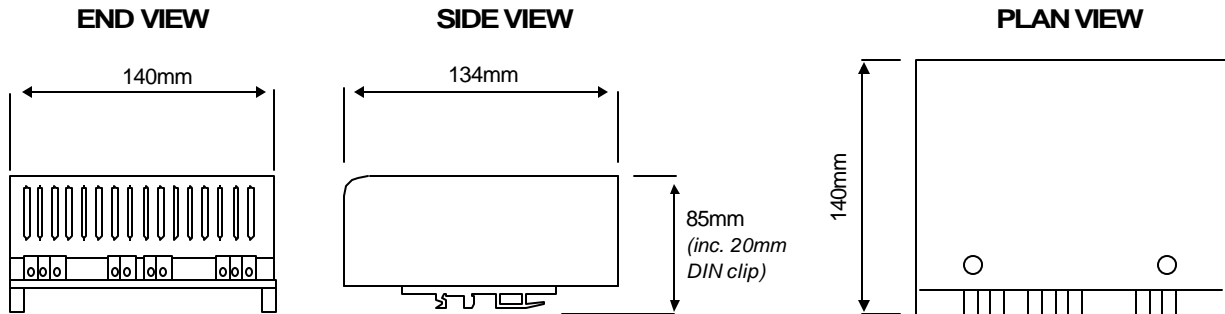

How to order

When ordering, please specify -

PRODUCT	Nominal Output VDC				Nominal Output Current			
	12	24	36	48	5	3	2	1.25
SM82125	•				•			
SM82245		•			•			
SM82243		•				•		
SM82362			•				•	
SM82481.25				•				•

	OPTIONS				
	Charge Fail	Manual Boost	Spade Connect	DIN Rail Mounting	Protective Cover
CF	•				
MB		•			
S			•		
DIN				•	
PC					•

CODE	INPUT VOLTAGE	
	95-135VAC	195-277VAC
E	•	
F		•

	BATTERY TYPE			
	Lead Acid	10 Cell Ni Cad	18 Cell Ni Cad	20 Cell Ni Cad
LA	•			
10		•		
18			•	
20				•

Product **Input volts** **Battery type** - **Options** **Options** **Options** **Options** **Options**

The above 3 part number codes must be filled in to complete your order

Insert options when required, if no options are required, leave empty

SM82125 F LA CF PC

The above example shows the order code for a 195-277V, AC input, 12V@5A, DC output charger calibrated for a vented lead acid battery, and with charge fail and protective cover options.

DIN Rail Clips are provided as standard when ordering the SM82 range of battery chargers in a protective cover.

North American Distributor - PC & S / Panel Components & Systems, Inc.		
149 Main Street Stanhope New Jersey 07874 Phone (800) 523 9194 Fax (973) 448 1674	213 Jespersen Avenue Spruce Grove Alberta T7X 2J1 Phone (877) 962 0557 Fax (780) 962 0557	8539 Monroe Road (Suite 104) Charlotte North Carolina 28212 Phone (704) 535 3357 Fax (704) 535 6288