

Enclosed SM135 12/24 Automatic Battery Chargers



Description

The SM135 is a highly efficient high performance charger. The very smooth output is configured for accurate fast charging and optimum battery life and reliability. The charger is designed to cater to continuous float charging and standby battery applications. Due to its very smooth output (< 1% ripple) the charger is suitable for sealed or vented batteries. The wide input voltage range, from 95-277V,AC allows the charger to be used with all common single phase voltages with no adjustment.

The SM135 charger is capable of being set up to provide 4 different charge voltage settings (2 nominal 12V,DC and 2 nominal 24V,DC) each with an adjustable boost setting. Boost is set by 4 voltage pots. The output voltage is set via a jumper placed across the appropriate pin header.

Switch mode technology is a major advance in power supply and battery charger design, giving low heat dissipation compact low weight design and ease of panel installation via panel mounted style enclosure. The unit comes complete with Ammeter indication.

Boost

A 'boost' mode of operation provides increased voltage output. Selection of boost mode is by shorting the Bst terminal to battery negative.

Charge fail

By connecting between C/F and battery negative a charge fail indication can be sensed.

Output Inhibit

The output inhibit value (*adjustable via R42*) shuts the charger off should the battery voltage be below the set value (normally 62% of nominal battery voltage)

- High rate duty float charging:
4.5A @ 12V,DC or 24V,DC
- User selectable output voltages
12 / 24V for Lead Acid / NiCad
- Fully automatic charge regulation
- Enclosed design with Ammeter indication
- Boost mode
- Charge fail relay output

Product Specification

Power Supply:

Nominal Operating Voltages	95-277V,AC
Nominal Operating Frequency	47-440Hz

DC Charge Output:

Output Current A,DC	4.5
Nominal Voltage V,DC	13 - 32V (fully adjustable)
Line Regulation	< 1%
Load Regulation	< 1%
Output Ripple	< 1%
Float / Boost Voltages	see table overleaf

Charge Fail Output:

Relay Type	volt free SPDT contacts relay de-energized on fault
Contact Rating	1A @ 30V,DC (resistive load)

General:

Operating Temperature	-10 to +55°C
Overall Dimensions (w x h x d)	140mm x 240mm x 110mm (6.5" x 2.2" x 6.1")
Weight	1.2Kg (2.6lbs)
EMC Emission / Immunity	EN 58801-2 / EN50082-2

Electrical connection

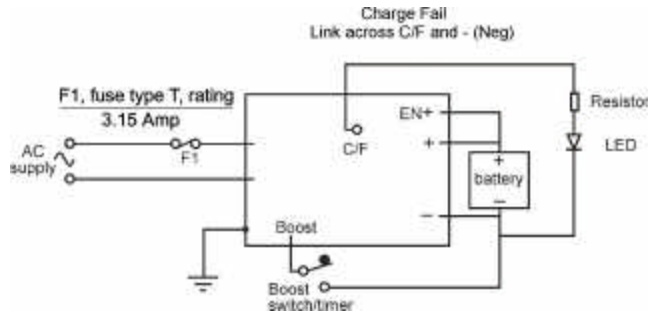

Notes:

- 1) battery output is isolated from chassis
- 2) chassis must be connected to a low impedance earth

Calibration

Battery type		float volts (VDC)	boost volts (VDC)
12V	Lead Acid (6 cells)	13.7	14.5
	Ni-Cd (10 cells)	14.2	14.7
24V	Lead Acid (12 Cells)	27.2	28.2
	Ni-Cd (20 Cells)	28.4	29.4

The above are factory standard settings. Different settings are available upon request.

Dimensions

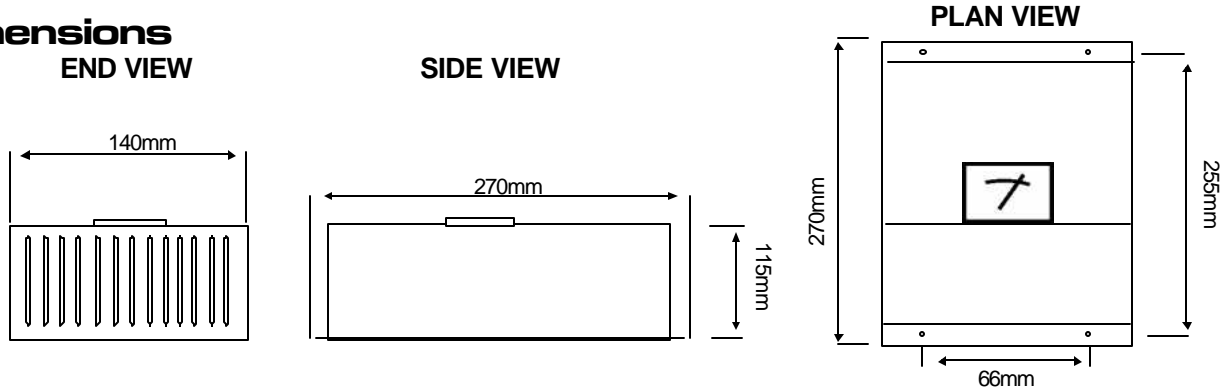

How to order

When ordering, please specify -

PRODUCT	Nominal Output VDC	Nominal Output Current
ESM1351224	12/24	4.5

CODE	INPUT VOLTAGE
CD	95-277VAC

	OUTPUT SELECTED			
	12V Setting L/A	10 CELL Ni-Cd	24V Setting L/A	20 CELL Ni-Cd
12VLA	•			
10		•		
24VLA			•	
20				•

Product	Input volts	Float voltage settings
ESM1351224	CD	12VLA

The above 2 part number codes must be filled in to complete your order

Insert settings and options when required, if product codes left empty, unit will be set at factory preset settings of 12VLA

The above example shows the order code for an enclosed 95-277V, AC input, 12V@4.5A, DC output charger, calibrated for a lead acid battery.

North American Distributor - PC & S / Panel Components & Systems, Inc.		
149 Main Street Stanhope New Jersey 07874 Phone (800) 523 9194 Fax (973) 448 1674	213 Jespersen Avenue Spruce Grove Alberta T7X 2J1 Phone (877) 962 0557 Fax (780) 962 0557	8539 Monroe Road (Suite 104) Charlotte North Carolina 28212 Phone (704) 535 3357 Fax (704) 535 6288